

ELECTRICAL HOB

Barcode : 8851737033548
Model name : HB60-2VC1TVC/TC

DETAILS:

Total connected load	5.7 kW.
Connecting cable	1 m without plug
Voltage	220 - 240 V
Frequency	50-60 Hz.
Type of command	Touch control with 9 power settings and independent 0-99 min. timer
Heating type	Vitro ceramic with ribbon heating element
Recommended wire size	10 sq.mm. (single-phase)
Recommended breaker size	40 A
Finish	Black ceramic glass
Built-in edging	Vertical edge
Cutting size:	560 x 490 mm.
Cabinet	600 mm.
Type of installation	Inset into the worktop from above
Minimum clearance between cooktop and hood	650 mm.
Minimum clearance between furniture:	150 mm. with thermal insulation fitted

Technical Drawing

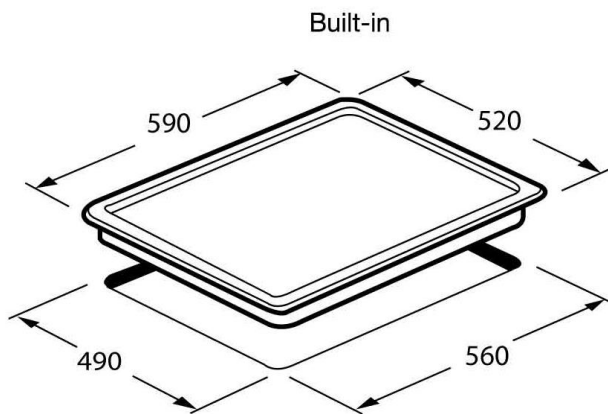

Technical detail

- Rare-left zone : \varnothing 165 mm. x 1,200 W.
- Front-left zone : \varnothing 200 mm. x 1,800 W.
- Right zone : \varnothing 300/220/150 mm. x 2700/1950/1050 W
- Dimension : 590 x 520 mm.
- Cutting size : 560 x 490 mm.
- Weight Gross : 10.1 Kg.