

ELECTRICAL HOB

Barcode : 8851737033845

Model name : HB73-2IND1DVC/TC

DETAILS:

Total connected load	5.5 kW.
Connecting cable	1 m without plug
Voltage	220 - 240 V
Frequency	50-60 Hz.
Type of command	Touch control with 9 power settings and independent 0-99 min. timer
Heating type	Hybrid (combination) induction and radiant
Recommended wire size	10 sq.mm. (single-phase)
Recommended breaker size	38 A
Finish	Black ceramic glass
Built-in edging	Vertical edge
Cutting size:	695 x 410 mm.
Cabinet	800 mm.
Type of installation	Inset into the worktop from above
Minimum clearance between cooktop and hood	650 mm.
Minimum clearance between furniture:	150 mm. with thermal insulation fitted

Technical Drawing

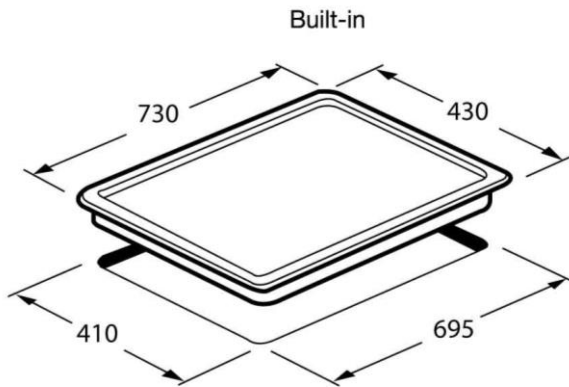

Technical detail

Left zone : Induction \varnothing 180 mm. x 2,000 W.

Middle zone : Induction \varnothing 180 mm. x 1,500 W.

Right zone : Radiant 200/120 mm. x 2,000/1,000 W.

Dimension : 730 x 430 mm.

Cutting size : 695 x 410 mm.

Weight Gross : 11.8 Kg.