



HOOD IN THE MIDDLE OF THE ROOM

PRODUCT CODE : 8851737052042

PRODUCT MODEL NAME : HI-iLLUMINA-90

Details :

Hood in the middle of the room, width 90 cm.

Stainless steel body and black tempered glass

Suction power 1,500 m³/h. Aluminum alloy motor frame, high heat resistance and not rust.

3 levels of wind power can be adjusted
touch control system

Perimeter Suction extraction system

Limitation of the area of the hood boosts air pressure easy to clean and reduce noise

Illumination type LED Panel Light 1 x 22W (6500K)

Aluminum oil mist filter that do not need to be removed for cleaning

Automatic shutdown timer

Technical information:

Product material Central room hood Stainless steel machine frame

Product size 90 cm.

sucking 1,500 m³/h.

Motor power 265 watt.

package size 960 x 455 x 665 mm.

Product weight 38 kg.

including packaging

Voltage 220-240 V

Frequency 50-60 Hz.

Air exhaust hole Ø150 mm. (6') with premium

Flexible pipe 1.5 m. in length

Product size and cut out dimension

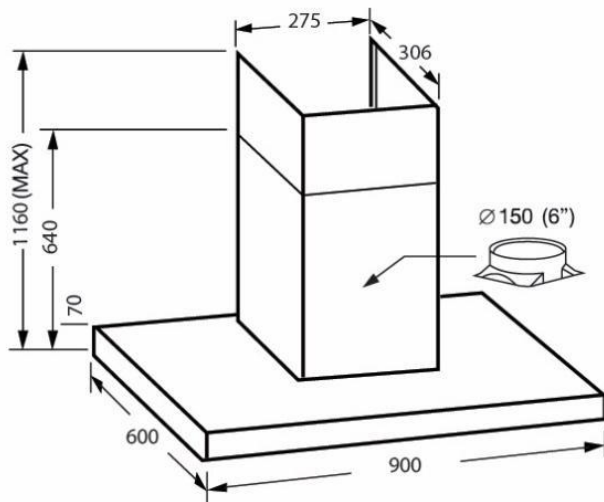

Equipment provided

1. Aluminum air duct, diameter 6 inches, length 2 meters.
2. throttle type air hose connector